

WIRE ROPE ISOLATORS: 'HELICAL'

DEFINITION
series CB1300

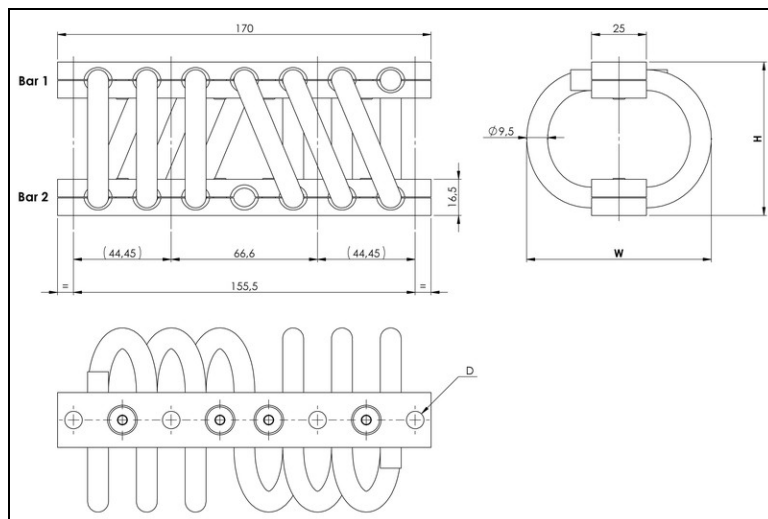

- All metal multidirectional anti-vibration/shock mounts
- Exceptional reliability and long life
- High damping
- No aging
- Corrosion resistant
- Unequalled temperature range : -180°C to +300°C / -290F to 570 F
- Great adaptability/versatility

Specials on request

(material size and number of loops, etc.)

Dimensions are in millimeters. For reference only

SERIES
Materials and finishes (meets RoHS requirements)
CB1300
Cable: stainless steel galvanized available: CBG
Retainer bars: aluminium alloy/ SurTec
Screws: alloy steel/ zinc plate
Inserts: stainless steel
All stainless steel: CBSS
Other materials on request

MODEL			
	height H (mm)	width W (mm)	weight (kg)
-12	68	80	0,71
-15	71	84	0,74
-20	74	90	0,76
-25	82	108	0,85
-30	77	104	0,82
-35	89	108	0,87
-40	105	121	0,96
-50	108	140	1,0
-60	124	143	1,1
-70	134	153	1,2
-80	155	180	1,3
-90	166	186	1,4

INTERFACES			
fixtures holes D	Bar 1		
	2 through holes ø7mm	2 through holes ø7mm counter-sunk 90°	4 inserts M6
Bar 2			
2 through holes ø7mm	no suffix	not standard	not standard
2 through holes ø7mm counter-sunk 90°	CM	CM2	not standard
4 inserts M6	IM	CIM	IM2

C B 1 3 0 0 - 1 2 C I M

SERIE: CB1300

'Helical' mount from the CB1300 series

MODEL: -12

height: 68mm

width: 80mm

weight: 0,71kg

loops: serie

standard is 06 loops

INTERFACE: CIM

2 through holes ø7mm

counter-sunk 90° in bar 1,

4 inserts M6 in bar 2



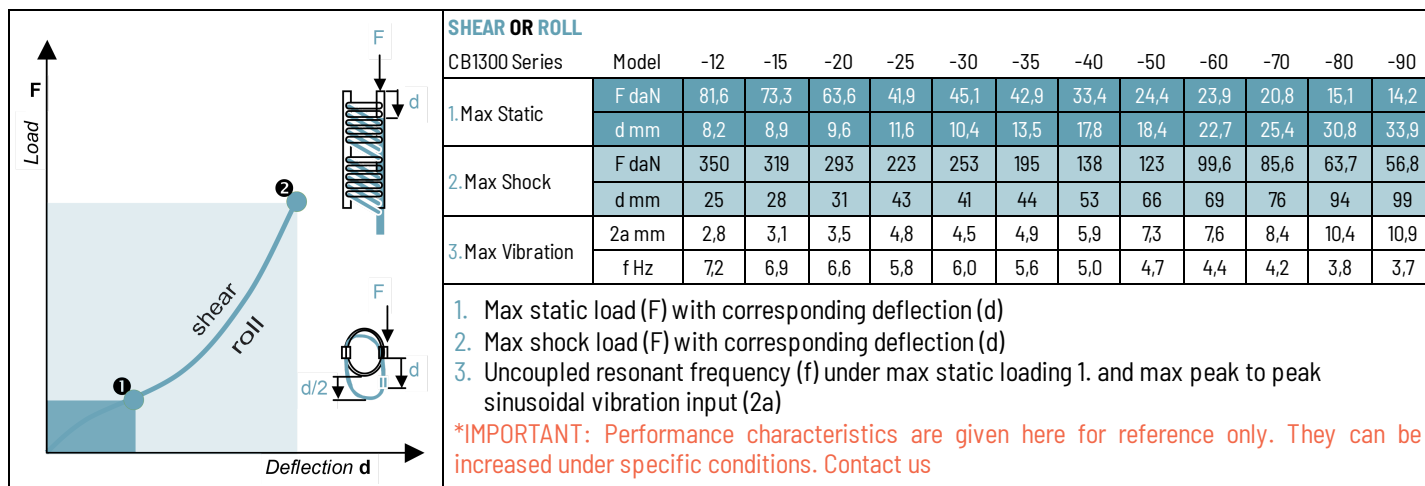
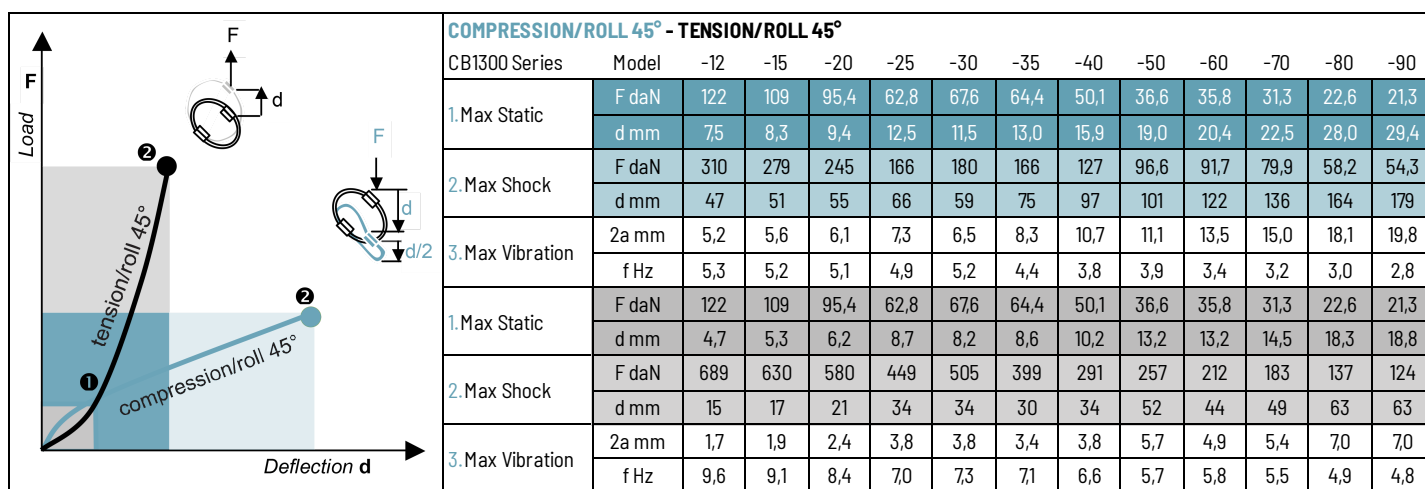
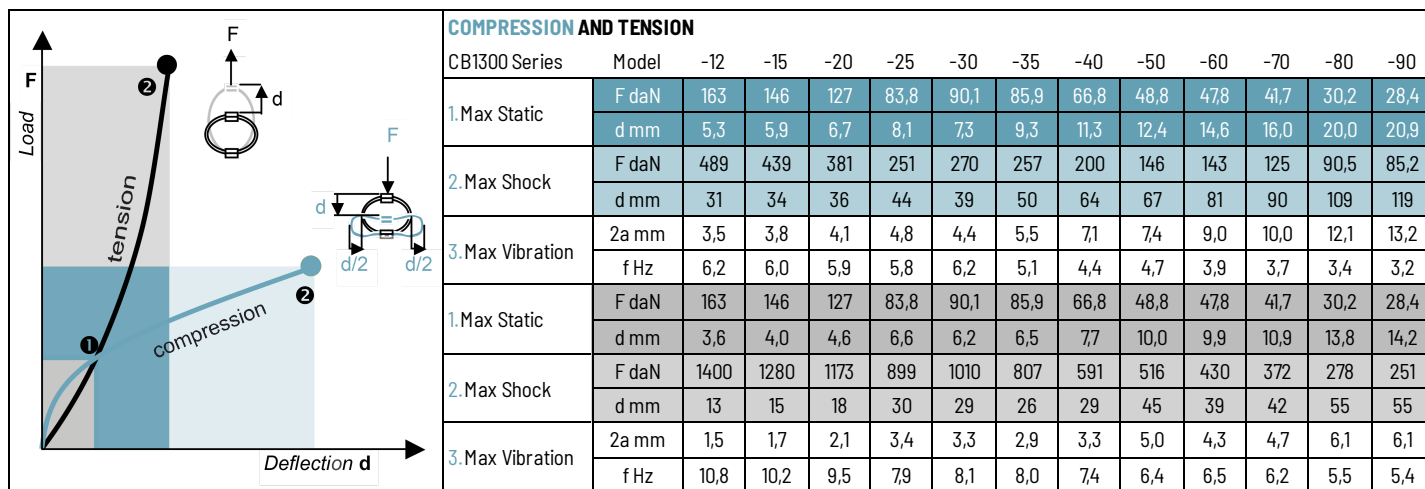

TYPICAL SHOCK/VIBRATION SPECIFICATIONS:

- Air** AIR 7306, MIL-E-5400, MIL-C-172, MIL-STD-810
- Ground Forces** GAM EG13A, SEFT 001, MIL-STD-810, VG 9533
- Marine** GAM EG13C, IT25-21/96-31/15-86, MIL-S-167, MIL-S-901, STANAG 042, BV 043.73, BV 044
- Others** GAM EMB1, GAM EMBT4, DEF STAN 07-55, IEC 571, FINABEL 2C